



AKAPP-STEMMANN

Member of the Fandstan Electric Group

4-Ductor®

Flexible with energy!



The perfect insulated conductor system
with continuous conductors for
current capacities 35, 50, 80, 125 and 160 A

AKAPP 4-Ductor® current supply system

Compact, reliable and safe current supply system for cranes, hoists, monorail systems, conveyor belts etc.

The basic design of AKAPP 4-Ductor is a channel housing, in which four slots are prepared to accommodate copper conductors. The flat conductors are installed **without the need for joints**.

Thanks to the design of the 4-Ductor and its continuous conductors, the system offers unique features as listed below.

Which advantages does 4-Ductor® offer you?

- **Excellent price/quality ratio.** The concept of the continuous conductors and the use of only high quality components result in a trouble free feeding system against an agreeable price.
- **High mechanical strength.** The PVC housing has a combination of high flexural yield, impact and tensile strength and is complemented by the design of associated components.
- **Continuous copper conductors.** The flat copper conductors can be pulled from rolls into the previously installed PVC housing in long continuous lengths, without any connections in the conductor.
- **Maximum power transmission.** The brushes are positively located in the PVC housing and contact with the flat copper conductors is maintained by spring pressure. This guarantees a positive contact and excellent power transmission.
- **High current capacity.** Copper conductors of various capacities can be pulled into the channels in the housing. Standard conductor capacities are 35, 50, 80, 125 and 160A.
- **Exceptionally long carbon brush life** is achieved due to the absence of conductor joints and connections which ensures trouble free operation.
- **Simple installation.** Due to the light weight of the PVC housing, copper conductors without connections and the design of accessory components, system installation is a quick and easy operation.
- **Safety to personnel.** The high level of volume resistivity of the PVC housing ensures absolute safety to personnel.
- **Virtually maintenancefree.** The PVC housing needs no maintenance and as previously mentioned continuous copper conductors ensure minimal brush wear. Thus minimising the presence of carbon deposits. Inspection periods can be scheduled in line with the schedule of the apparatus to be fed (i.e. a crane).
- **No expansion problems.** Due to the clearance that exists between the conductors and their location and the clearance between the PVC housing and sliding hangers, expansion due to changes in ambient temperature is accommodated without affecting the operation of the system. This also applies to extra long installations where standard components eliminate expansion problems often experienced with alternative systems.
- **Volt drop absolute minimum and constant** due to continuous copper conductors, thus avoiding problems associated with added resistance at joints and increased volt drop characteristics when joints loosen or corrode.
- **Compact design.** By virtue of design, the 4-Ductor system utilises an absolute minimum of space.

Please note that, due to continuous innovations, technical specifications and performances listed in this catalogue, are subject to change without notice.

For some applications, it is necessary to use the **AKAPP Multiconductor® system** (please refer to separate brochure). Typical examples are as follows:

- 5 to 7 conductors are to be installed in one housing;
- the system requires protection using flexible sealing strips;
- the installation requires the use of transfer guides or isolation sections;
- the travel speed is in excess of 60 m/min.;
- a combination of the above.

PVC housing

Type RN4

with 4 conductor slots to accommodate 4 copper conductors.

Colour: grey (appr. RAL 7000)

Temperature range -30°C to +60°C.

The anti-reverse rib (A) in the housing ensures that the collector trolley can only be installed in one way and prevents cross phasing. A continuous yellow stripe (B) on one side of the housing ensures correct fitting of the system. The PVC with a high impact strength is self-extinguishing

Technical data of the housings

Material data	
Unplasticized Hard-PVC with approximate values:	
Notch shock strength	5-10kJ/m ²
E-modulus	2500-3000N/mm ²
Softening point (Vicat)	81-83°C
Linear expansion	70.10 ⁻⁶
Electrical data	
Volume resistivity with 100V	>4.10 ¹⁵ Ω/cm
Dielectric strength with 50 Hz	>30 kV/mm

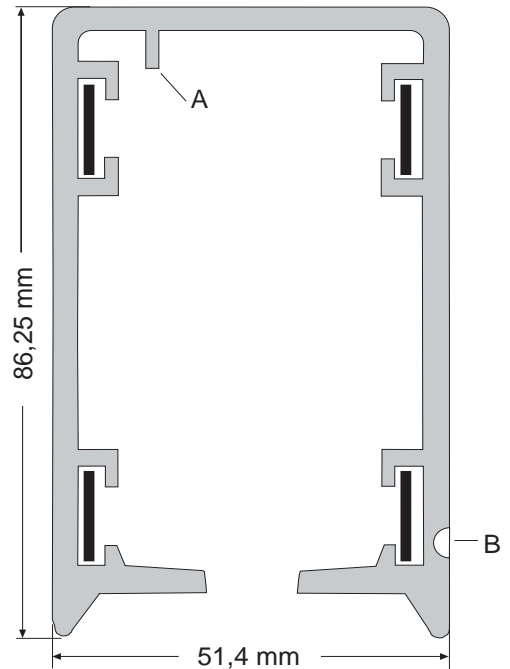

Length of housing is standard 4 m; Special lengths are available.

Copper conductors for housing RN4

Each 4-Ductor installation is supplied with continuous flat copper conductors to suit the system length.

Copper conductors type CU35, CU50, CU80, CU125 and CU160 for current capacities 35, 50, 80, 125 and 160A (duty cycle 80%) Material electrolytic copper.

Maximum lengths of continuous conductor strip that can be pulled into the conductor housing: Cu35 and Cu50: 300m; Cu80: 250m; Cu125: 200m; Cu160: 150m

Attachments for 4-Ductor housing

Sliding hanger

Type BN7-Z: galvanised;

Type BN7-L: galvanised + epoxy coating.

Center distance of hanger supports:

2000 mm : possible for installations with conductors Cu35, Cu50 and Cu80;

1333 mm : all installations.

Fixed point clamp

Type VMN7-Z: galvanised;

Type VMN7-L: galvanised + epoxy coating.

The system should be secured to the support construction adjacent to the electric feed point via a self clamping fixed point and then from this position free expansion is allowed to take place. When required, 2 provided self drilling screws can make the connection extra secure.

Joint clamp

Type VN7-Z: galvanised;

Type VN7-L: galvanised + epoxy coating.

The lengths of housing are connected by means of standard joint clamps. The clamps have special fixations whilst fitting the clamp halves. When required, 2 provided self drilling screws can make the connection extra secure.

Insulating tape

Type T50. 50 mm width, roll of 10 m. This adhesive tape is used to ensure a permanent shroud around the housing joints, prior to fitting the joint clamps.

Support bracket, galvanised C-profile

Type UH330, length 330 mm

Type UH500, length 500 mm

Type UH700, length 700 mm

These brackets have clamps attached to sliding nut assemblies thus facilitating a flexible mounting arrangement capable of accommodating various sizes of RSJ (INP) beams, allowing simple horizontal adjustment.



BN7



VMN7



VN7

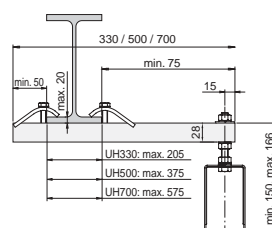
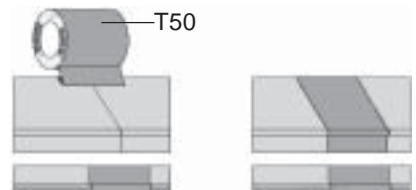

UH

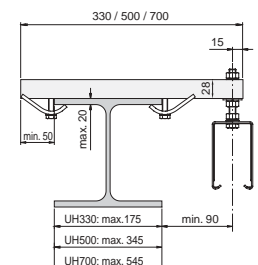

End feed boxes

End feed box type AK7-28

This box is supplied with connecting screws for connecting the supply cable cores (up to 4 cores) to the copper conductors. Feeding in via a cable gland Pg29 for cables $\varnothing 10\text{-}\varnothing 28$ mm, e.g. 4 x 25 mm².

AK7-28



End feed box type AN4-18

A small end feed for connecting small cables up to $\varnothing 18$ mm. Length 200 mm. To attach this end feed box to the conductor housing a joint clamp is required (ordered separately).

AN4-18



Line feed boxes

Line feed box type LK28

Feeding in via a cable gland Pg29 for cables $\varnothing 10\text{-}\varnothing 28$ mm, e.g. 4 x 25 mm².

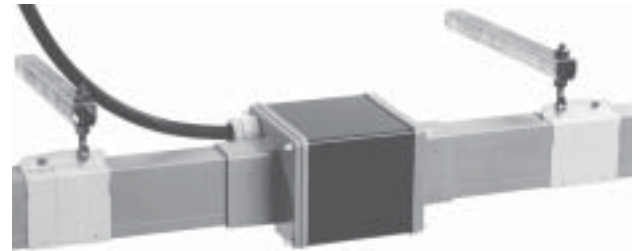

LK28

Line feed box type LK21-4

Performance equal to LK28, however supplied with 4 cable glands Pg21 for single core cables $\varnothing 10\text{-}\varnothing 21$ mm (25 mm² and above). The feed connection comprises a transition box. AKAPP can inform you about the available types.

Feed cables for line feed box LK21-4

Single core cables, standard length 1,5 m. Provided with 2 cable lugs (1 fitted at cable end and 1 separately)

Type OK25 (1x25 mm²), $\varnothing 14,9$ mm;

Type OK35 (1x35 mm²), $\varnothing 15,3$ mm;

Type OK50 (1x50 mm²), $\varnothing 18,2$ mm;

Type OK70 (1x70 mm²), $\varnothing 20,8$ mm.

LK21-4



Line feed housings

Connecting possibilities for feed cables when line feed is used.

Line feed housing type LRNK4

Length 1000 mm, supplied with 4 notches in which the feed clamps VKK and VKG fit. The housing is mounted by means of 2 joint clamps in the 4-Ductor system and is secured to the support construction by 2 fixed point clamps.

LRNK4



Feed clamp type VKK, with bolt M6/M8, for copper conductors Cu35 and Cu50;

Feed clamp type VKG, with bolt M8/M10, for copper conductors Cu80, Cu125 and Cu160.

VKG



Line feed box type LRN4

2 pieces of housing 500 mm each, with 4 notches for protruding copper conductor ends. The housing is mounted by means of 2 joint clamps in the 4-Ductor system and is secured to the support construction by 2 fixed point clamps.

LRN4



End cap type EN4

Length 200 mm. For closing off the open ends of a 4-Ductor system. Fitted to the housing by means of a joint clamp (ordered separately).

EN4



Collector trolleys

The current is fed from the Multiconductor to static or mobile equipment via the collector trolley. The actual connection to the flat conductors is via spring loaded carbon brushes which are manufactured from a special bronze/carbon alloy having a high wear factor. The collector trolley is pulled along the 4-Ductor installation by the apparatus/machine being fed, on which the towing arm is mounted. The standard collector trolleys are suitable for traverse-speeds up to 60 m/min.

Standard collector trolleys

Collector trolleys are available for 4 conductors with current carrying capacities of 35, 70 and 100A; duty cycle 60%. The 70A trolleys and 100A trolleys are formed by mounting 2 resp. 3 separate trolleys 35A on a metal strip (see the figures opposite). Existing trolleys can be easily transformed.

All collector trolleys can be delivered with or without 1 m tail (type "C4-..", resp. "CL4-..").

It is recommended to use a transition box when connecting the trolley with the apparatus to be fed (see figures below). This box (order separately) can be mounted close by on the apparatus or machine.

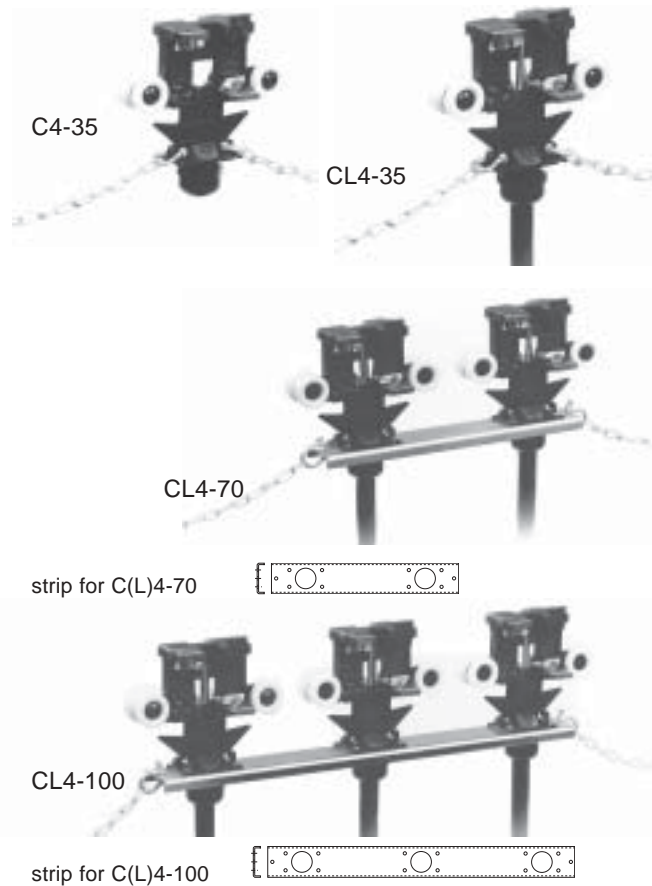

Transition boxes for collector trolleys

This unit facilitates the connection of the flexible cable from the collector trolley with the fixed wiring from the apparatus/machine being fed. Using the included attachments, the transition box can be mounted easily on the (AKAPP) towing arm or close by on the apparatus/machine.

Types of transition boxes:

type	for trolley	inlet	outlet
OG35-7	C(L)4-35	1xPg21	1xPg21
OG70-5	C(L)4-70	2xPg21	1xPg29
OG100-5	C(L)4-100	3xPg21	1xPg36

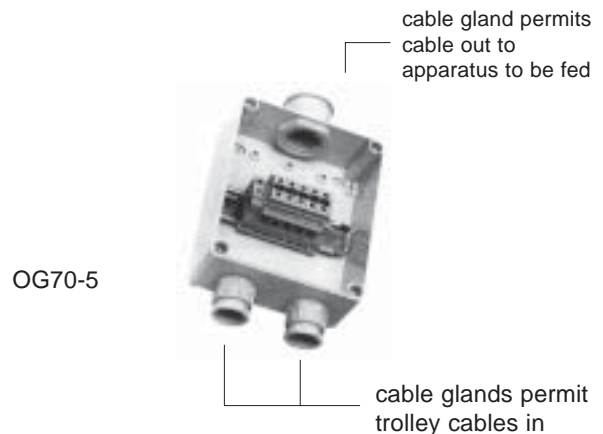

Trolley towing arm

Types BMV35, BMV70 and BMV100, for collector trolleys resp. 35A, 70A and 100A.

A towing arm is attached to the moving machinery and connected to the collector trolley via chains. The arrangement is such that when pulling in either direction one of the collector towing chains is taut, the other remaining slack. In this way lateral movements of the crane, hoist, etc. are not transmitted to the trolley. This tolerance provides **ultimate security of service!**

Attention: The towing connector on the arm should be installed 10 mm lower than the towing connection on the trolley in the highest position and at 30 mm lower than the towing connection on the trolley in the lowest position and should be aligned directly below the housing opening in the vertical plane.

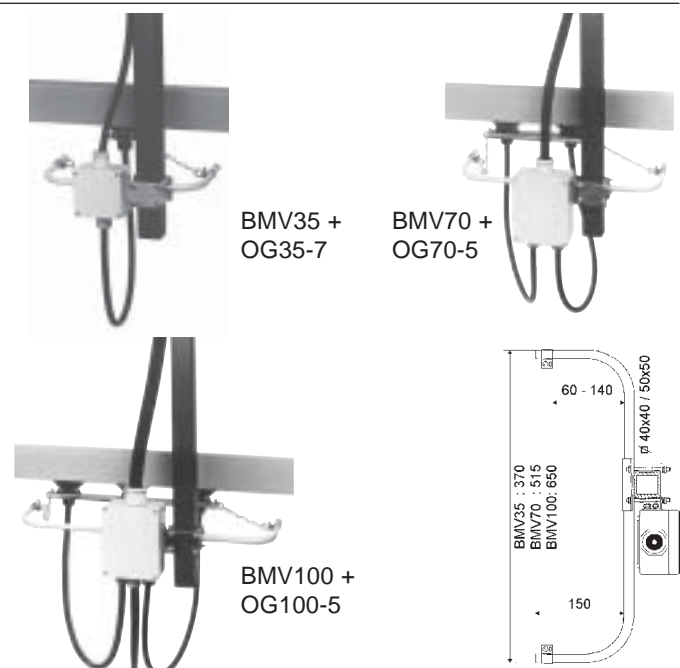

4-Ductor system configuration

A. Installation with end feed box (AK)

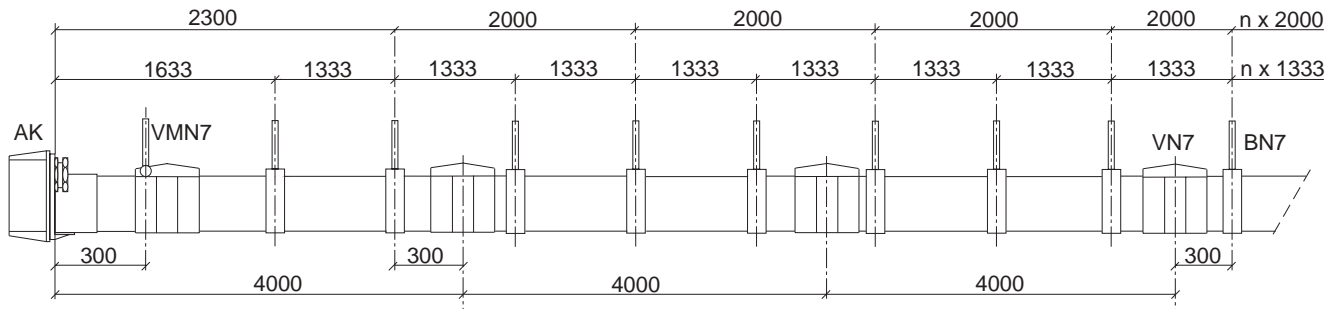

B. Installation with line feed box (LK)

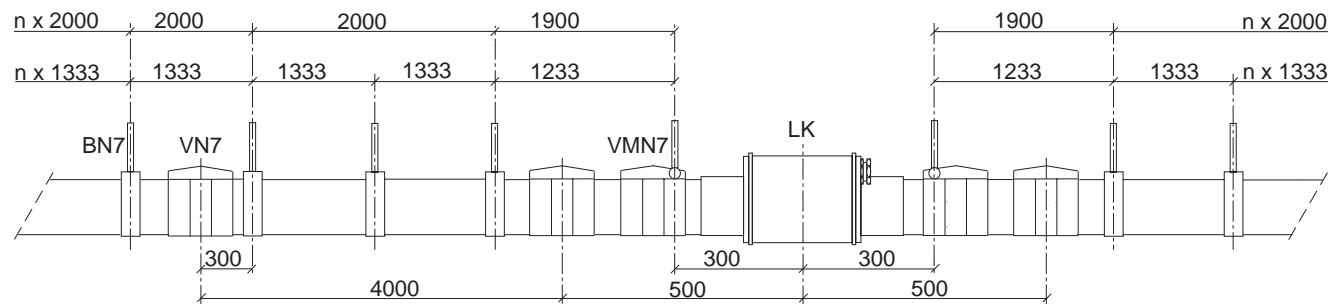

Note:

In the examples above there are two possibilities shown for the centre distance of the support hangers. We recommend:
 1333 mm: all installations
 2000 mm: only possible when copper conductors max. 80A are used

AKAPP-STEMMANN offers you more!

AKAPP-STEMMANN products are used all over the world in many various applications and circumstances.



AKAPP-STEMMANN is represented worldwide in over 40 countries.

Our wide product range offers solutions for numerous problems concerning mobile power feed systems. No wonder that AKAPP-STEMMANN has a leading position!

AKAPP-STEMMANN has a long term experience and therefore our staff offer you fast and expert advise; free of charge!

For free copies of catalogues as listed opposite, or product information, please contact your AKAPP-STEMMANN supplier or visit our web site.

AKAPP-STEMMANN offices:

The Netherlands (head office)

Nijverheidsweg 14
 3771 ME Barneveld
 Tel. (+31) 342-403900
 Fax (+31) 342-403912
 e-mail : info@akapp.com
 Internet : www.akapp.com

Belgium

Tel. (+32) 15-281718
 Fax (+32) 15-281701

Germany

Tel. (+31) 342-403939
 Fax (+31) 342-403922

- Multiconductor (multipole insulated current rail)
- Monoconductor (monopole insulated current rail)
- Pro-Ductor (multipole insulated flat current rail)
- T-bar systems
- Self winding cable and hose reels
- Spring driven cable and hose reels
- Motor driven cable and hose reels
- Portable hand winded reels
- Slip rings
- Festoon systems
- Plastic and steel energy chains
- Special cables
- Grounding reels
- Balancers

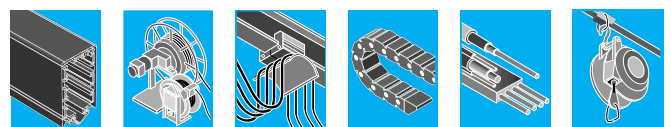

Your AKAPP-STEMMANN supplier: