

Flexible with energy!

The ideal industrial cable reels for perfect automatic winding of cables in practically every application, as well indoors as outdoors.

The unique construction has been designed in view of :

- **safety:** electrical as well as mechanical
- **convenience:** easy installation and maintenance
- **reliability:** built of components on which high demands can be made.



The electrical heart of the cable reel is a modular collector ring, designed to accommodate overloads and provide for long service life.



A large junction box features a weathertight seal to assure safe, consistent protection from the elements.



Some important characteristics:

Mainspring: Self-contained; made from special alloy spring steel in a controlled manufacturing process, which meets extremely high requirements. Through this, optimal repeatability and long spring life are assured. The spring is packed in a metal cassette, which enables a quick, safe and easy exchange.

Collector rings: The collector rings are made of eminent brass. The carbon brushes have a large surface which ensures a perfect contact with the collector rings. Each brush is mounted in a non-conductive holder. The modular construction of the collector rings makes easy expansion and service possible.

Cable guide: The application of the fully adjustable guide arm with roller guide prevents deformation of the cable, e.g. bending. This increases the service life of the cable.

Advantages of the guide arm are:

- numerous settings over a maximum arc
- fast, easy adjustment
- optimal location with respect to the cable drum
- secure positioning
- non-contoured guide rollers, which prevent torsion of the cable

Ratchet: This can be activated for use without traction force with e.g. hand tools. Location is fixed with respect to the cable connection, ensuring that the reel can never be "locked out" when the cable is totally unwinded.

Construction: Weathertight construction, manufactured from aluminium die cast components. Provided with a corrosion resistant powder polyester coating in a striking yellow colour. The design minimizes the number of components, allows for easy replacement to reduce maintenance costs.

Additional features

- cable capacity max. 15 m
(\varnothing 16 mm / 0,37 kg/m, e.g. 5x2,5 mm² H07RNF)
- standard fitted with 4, 5, 8 or 12 collector rings
- large connection box for quick and safe cable mounting
- collector capacity 30A / 600V

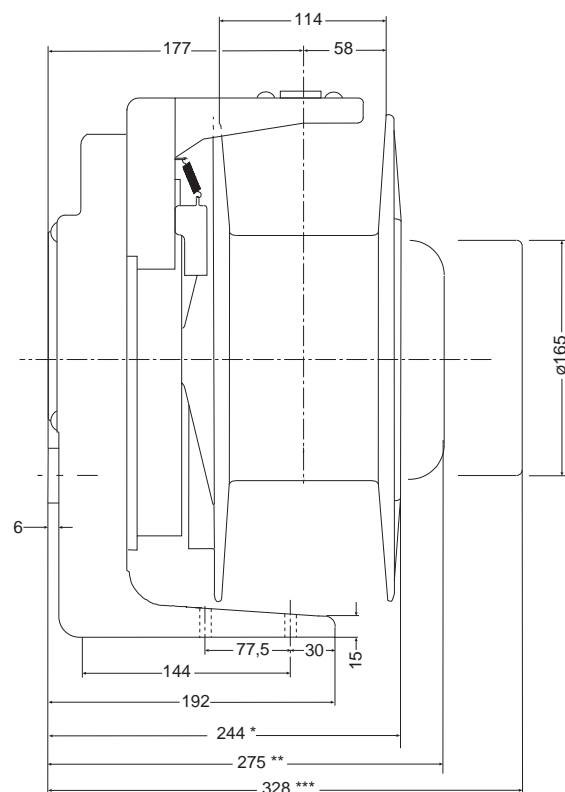
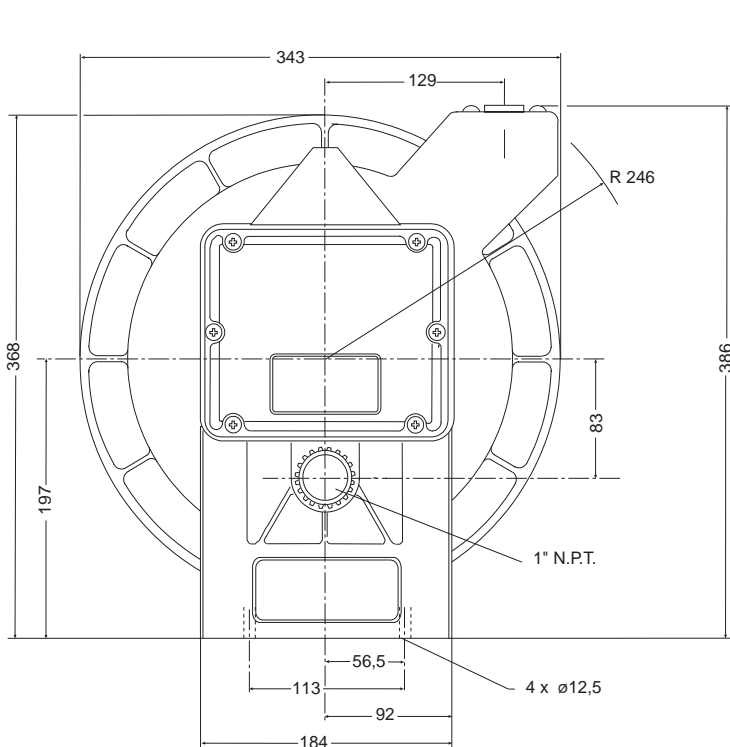

(Dimensions in mm)

*max. 5 sliprings
 **max. 8 sliprings
 ***max. 12 sliprings

Some important mounting directions

The reel should be mounted with the main shaft level, and with the spool in-line with the cable termination. This allows the cable to pay out and rewind without coming in contact with the frame. The cable guide feeds the cable to the center of the spool. This should **never** be used as a **sheave** or to turn cable in a direction other than in-line with the spool. The position of the guide arm with the roller guide must be adapted to the winding direction. This can be done easily.

The reel needs a number of pre-tensioning turns to properly load the spring so that, when the cable is wound, there is still a small tension: the **pre-tension**.

The adjustment of this pre-tension is very important, because it assures the best performance of the reel and maximum spring life.

The number of pre-tensioning turns depends on the cable to be wound.

Technical changes under proviso.

For free advise and further information about AKAPP spring driven reels or other mobile power feed systems, please contact our Head Office.

We will be pleased to send you detailed catalogues about our products.

The AKAPP-STEMMANN program:

- Conductor bar systems
- Festoon systems
- Reeling drums
- Sliprings
- Drag chain systems
- Special cables

Holland:

Nijverheidsweg 14
 P.O. Box No. 54
 NL-3770 AB Barneveld
 Tel. : (+31)342 403900
 Fax : (+31)342 403912
 E-mail : info@akapp.com
 Web : www.akapp.com

