

Flexible with energy!

The standard cable reel series "AV" covers a large spectrum of applications and requirements. The range is divided in five standard types depending on the winding capacity. The cable reels can be used for practically every application, indoor as well as outdoors.

Safety and reliability are our main focus, for this reason all cable reels comply with the most recent EU regulations (CE-marking).

Furthermore all cable reels have been constructed of high quality components and are subject to stringent quality demands.



The modular collector ring accommodates extensive variations and ensures reliability due to the large carbon brushes and the synthetic housing. The material used is weather tight (corrosion resistant). Protection degree IP65/66.



The series AV-cable reels can be finished with a polyester coating, for optimal protection against corrosion.



Some important characteristics:

Mainsprings: Made of high-grade special steel for optimal performance and long lifetime. The springs are mounted into a metal housing to prevent friction and wear. The special construction of the cable reel shaft ensures quick and easy replacement of the springs.

Collector rings: The modular collector ring body is designed to accommodate extensive combinations.

The possibility exists to i.e combine feed-and control signals. Transmission of data- and video signals is possible as well. For an optimal reliability silver or gold plated collector rings are applicable.

The collector ring body is covered by a glass-fibre reinforced synthetic housing with ventilation valve. The housing is weather resistant and corrosion proof and the glands and seals are water tight. Protection class in accordance with standard IP65/66.

Construction: Solid steel housing, hot dip galvanised or with corrosion proof polyester coating. Upon request external fitted bolts and nuts can be supplied/fitted in stainless steel and all other structural parts can supplied/fitted as hot dip galvanised or with a polyester coating. The galvanised mounting flange offers a secure fitting of the reel to any construction.

Range of types:

- Type 190** drum-Ø 190 mm. For max. 30 m cable Ø12 mm, weight 0,25 kg/m or 11 m cable Ø20 mm, weight 0,55 kg/m
- Type 280** drum-Ø 280 mm. For max. 60 m cable Ø18 mm, weight 0,45 kg/m or 29 m cable Ø24 mm, weight 0,8 kg/m
- Type 400** drum-Ø 400 mm. For max. 88 m cable Ø22 mm, weight 0,7 kg/m or 50 m cable Ø34 mm, weight 1,6 kg/m
- Type 500** drum-Ø 500 mm. For max. 115 m cable Ø26 mm, weight 0,95 kg/m or 65 m cable Ø36 mm, weight 2,25 kg/m

Other features:

- Capacity of sliprings up to max. 200A at 660V (depending on reel type)
- Complete with easy to mount fixing flange
- Special sizes on request

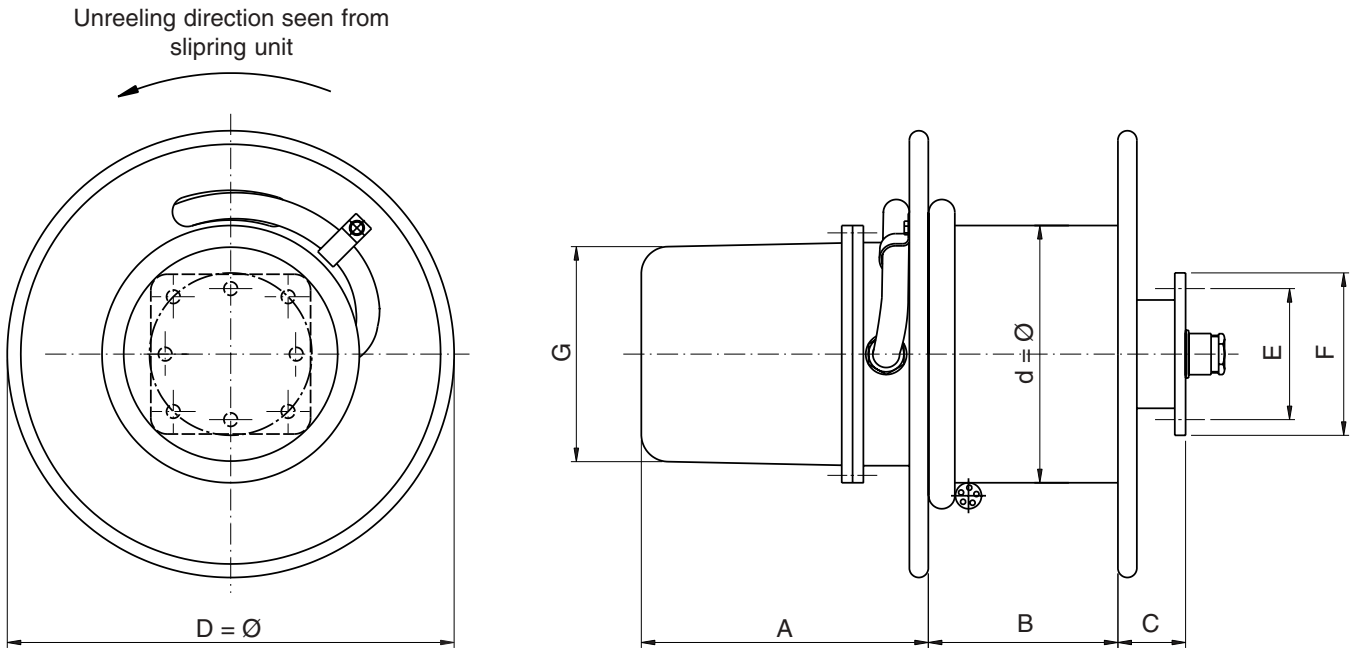

(Dimensions in mm)

| SERIES | A | B | C | d Ø | D Ø | E Ø | F | G Ø | Weight (kg) |
|--------|----------------------------|-----------|----|-----|-------------------|-----------|-----|-----------|-------------|
| 190 | depending on slipping body | 136 | 48 | 190 | 290/360 * | 100/125 * | 120 | 140 | 11 - 15 * |
| 280 | | 180/215 * | 48 | 280 | 430/500 * | 100/125 * | 120 | 140/205 * | 22 - 33 * |
| 400 | | 280 | 57 | 400 | 560/630/710/800 * | 140 | 140 | 205/360 * | 54 - 86 * |
| 500 | | 280 | 58 | 500 | 710/800/900 * | 140/180 * | 160 | 205/360 * | 82 - 90 * |

* depending on reel type

Some important mounting directions

The reel should be mounted with the main shaft level, and with the spool in-line with the cable termination. This allows the cable to pay out and rewind without coming in contact with the frame.

The reel needs a number of pre-tensioning turns to properly load the spring so that, when the cable is wound, there is still a small tension: the **pre-tension**. The adjustment of this pre-tension is very important, because it assures the best performance of the reel and maximum spring life.

The number of pre-tensioning turns depends on the cable to be wound.

Technical changes under proviso.

For free advise and further information about AKAPP spring driven reels or other mobile power feed systems, please contact our Head Office or visit our website.

We will be pleased to send you detailed catalogues about our products.

The Netherlands:

Nijverheidsweg 14
P.O. Box 54
NL-3770 AB Barneveld
Tel. (+31)342 403900
Fax (+31)342 403912
Web: www.akapp.com

More AKAPP products:

- Conductor systems
- Festoon systems
- Reeling drums
- Sliprings
- Energy chains
- Special cables



AKAPP-STEMMANN

Member of the Fandstan Electric Group

