

Fixed to electric travel trolley (perpendicular version)

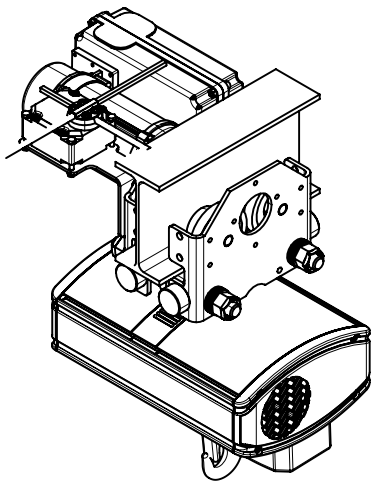
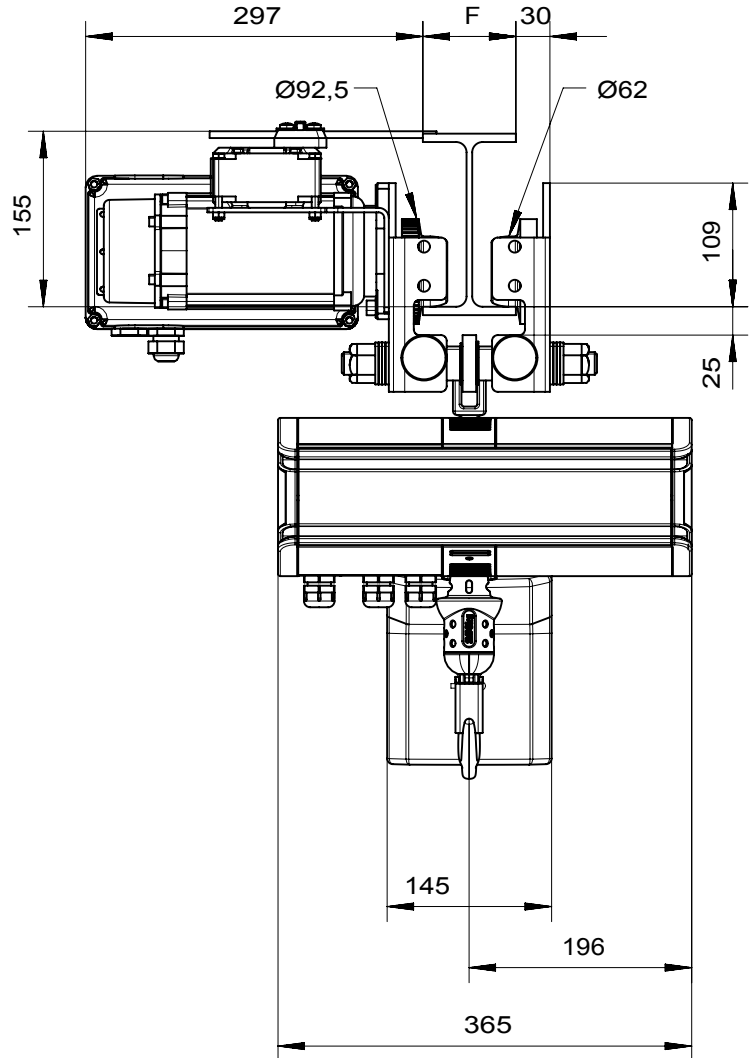
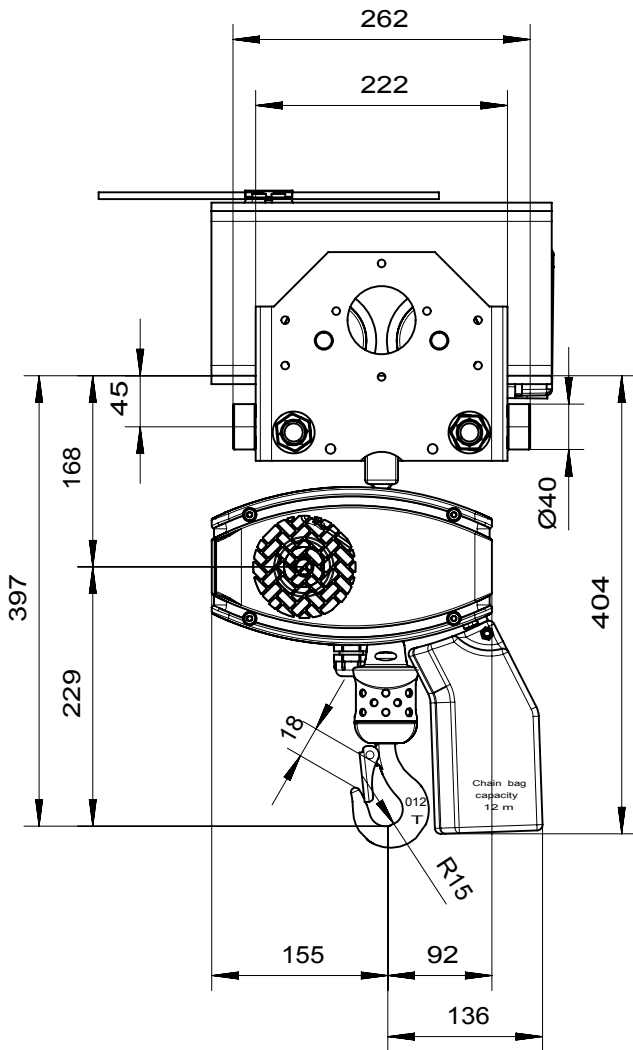

$$55 < F < 310$$

	Without chain	With 3m of chain
Weight	40.3 kg	41.5 kg