

Fixed to push trolley (perpendicular version)

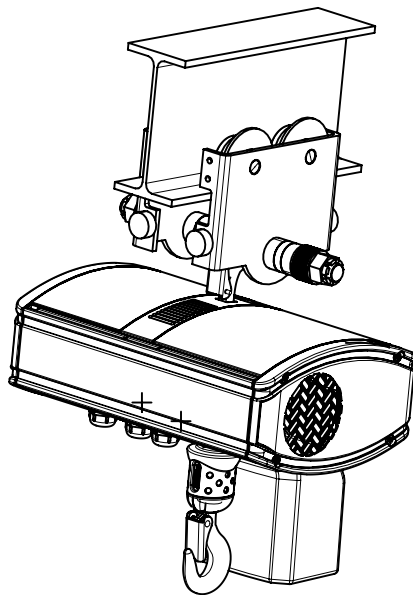
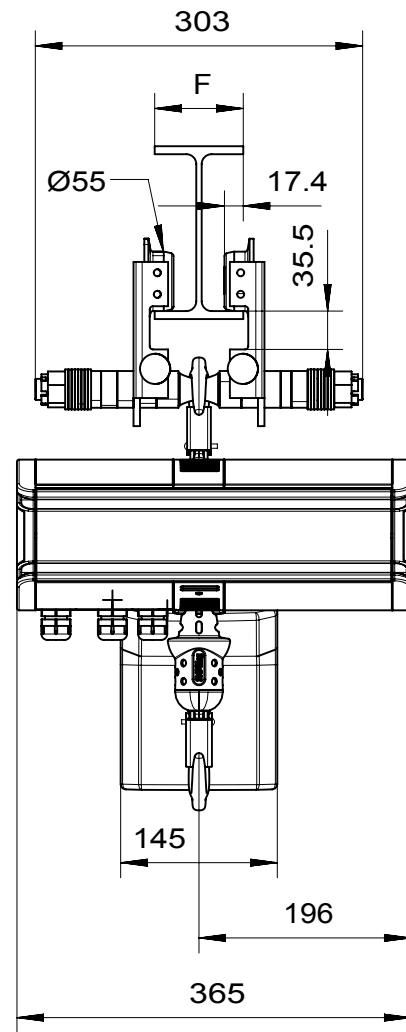
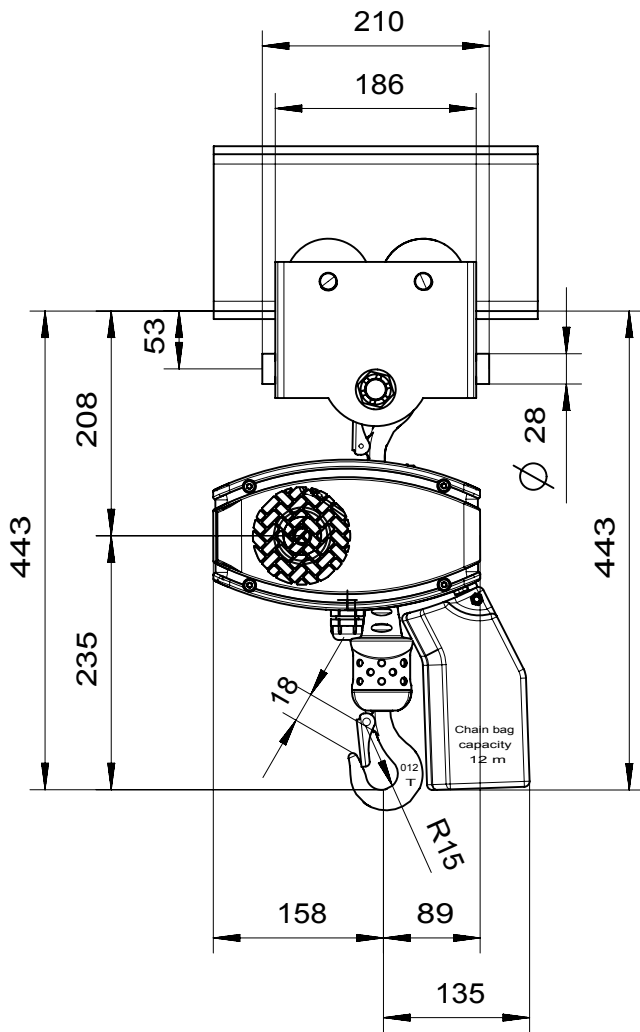

$50 < F < 200$

	Without chain	With 3m of chain
Weight	25.5 kg	26.7 kg