

Fixed to normal electric travel trolley C2 - Dual falls (perpendicular version)

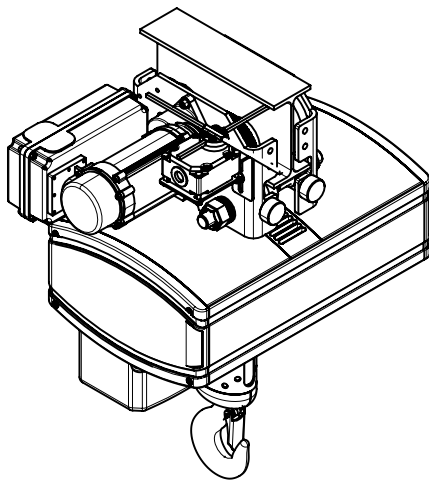
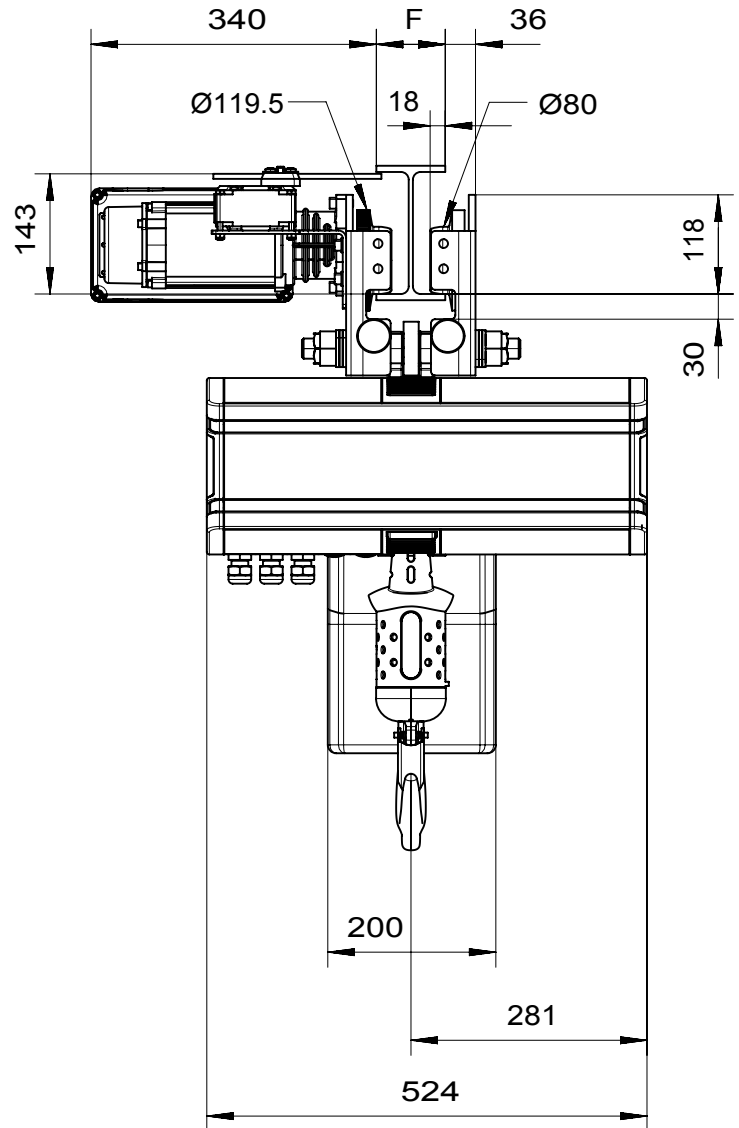
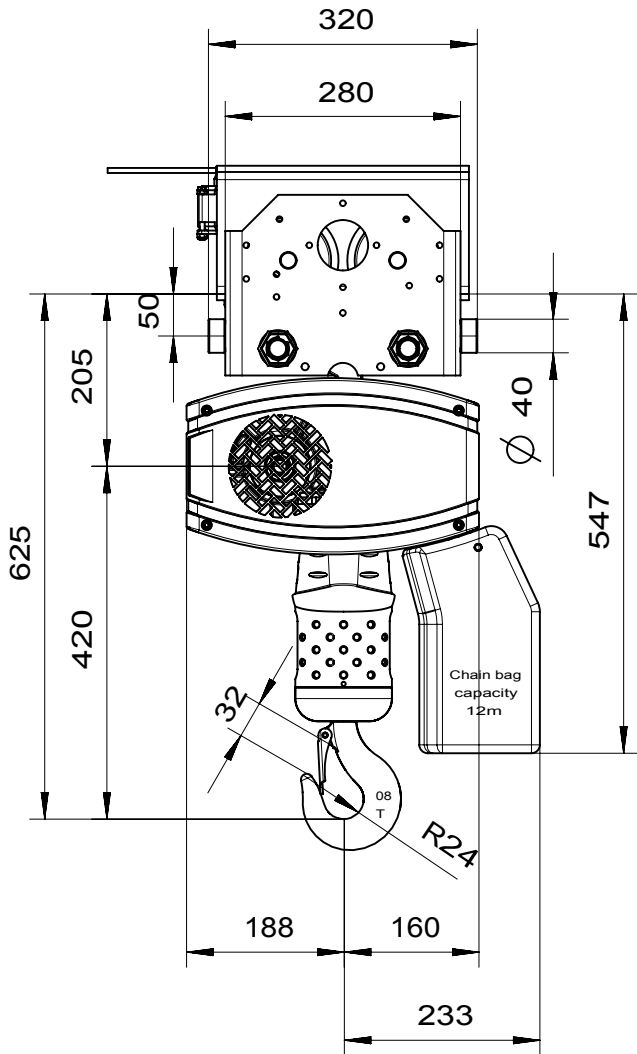

$$64 < F < 310$$

	Without chain	With 6m of chain
Weight	90.1 kg	93.4 kg