

Fixed to push trolley HPT 1000kg (perpendicular version)

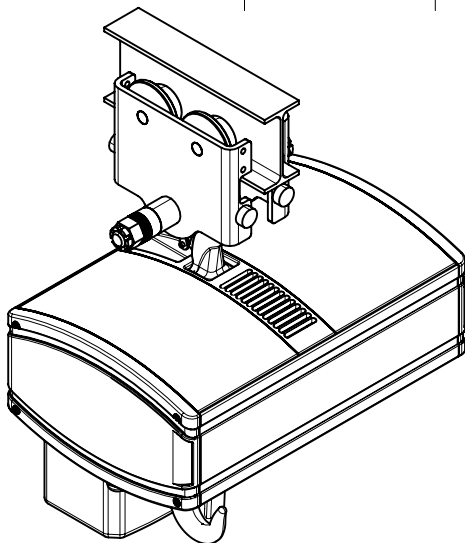
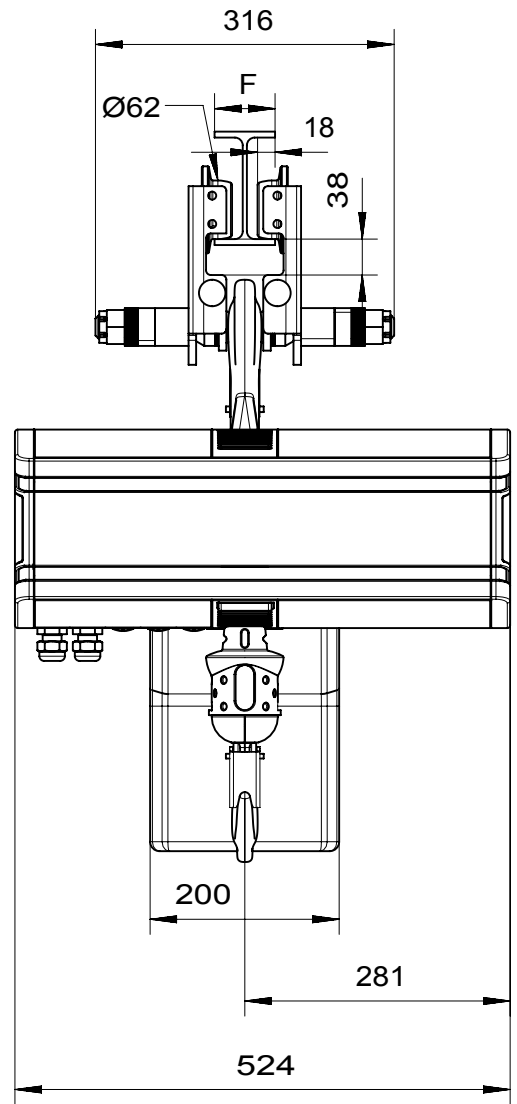
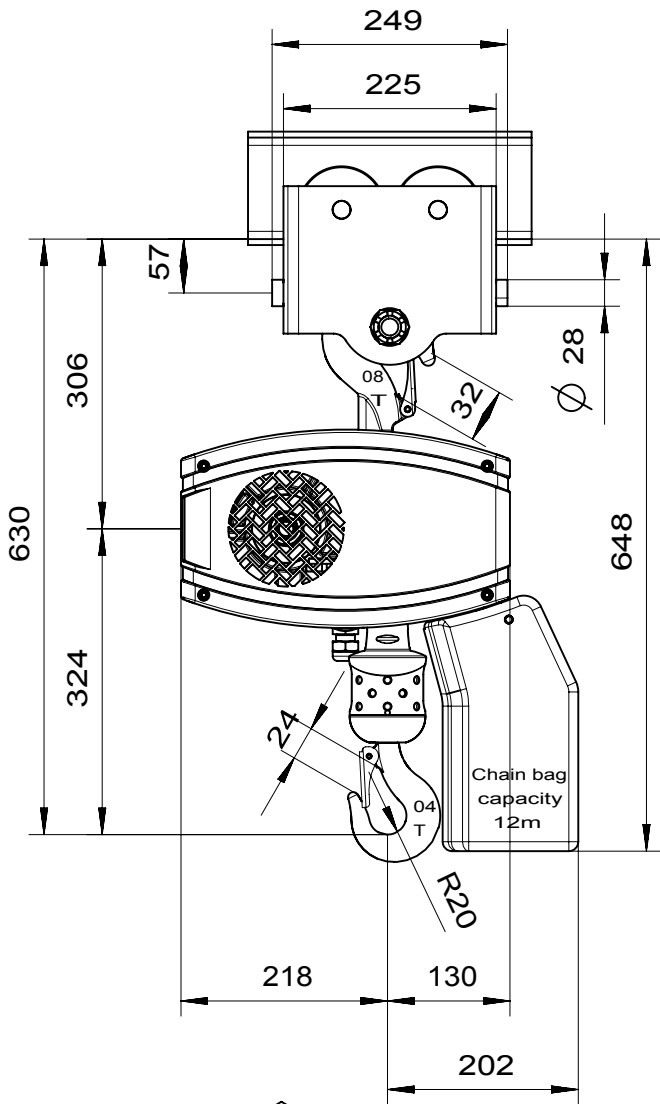

$$65 < F < 200$$

	Without chain	With 3m of chain
Weight	61.1 kg	64.4 kg