

Accouplé à C3 chariot manuel (version perpendiculaire)  
Fixed to push C3 trolley (perpendicular version)  
Ösenaufhängung mit C3 Schiebefahrwerk (Quer zur Kettenzugachse)

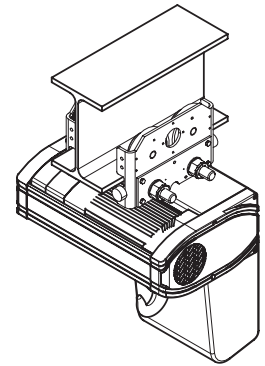
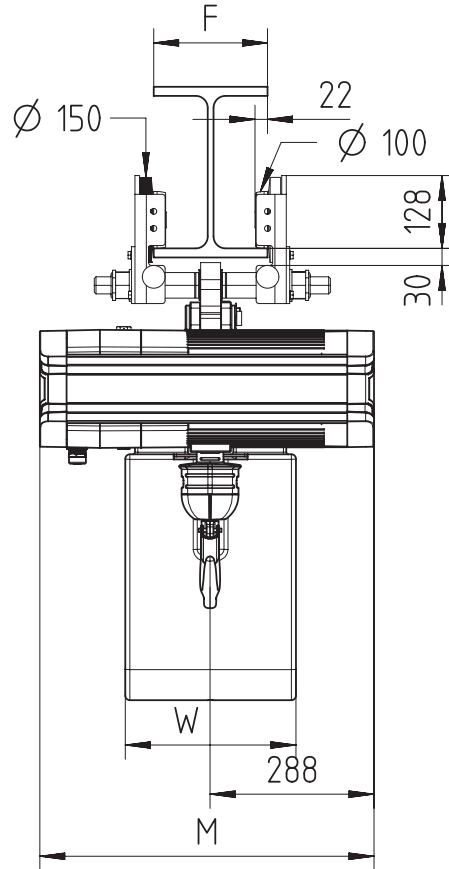
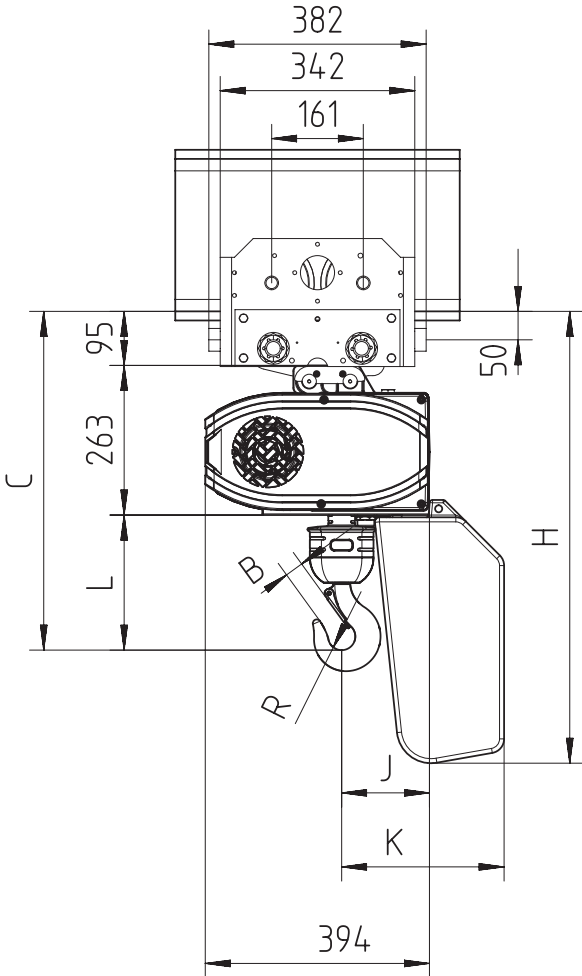

Chain Size [mm]	Falls	Chain bag max capacity [m]	Max load kg	Dimensions [mm]								Weights [kg]						
				B	C	L	R	J	K	H	W	M		Weight of 3m of chain	Total weight w/o chain			
												Classic/ GLS	Neo/ DB		Classic	Neo	GLS	DB
11.3X31	1	12	2500	33	596	238	24	154	286	794	300	587	709	8.4	155.2			
11.3X31	1	30	2500						397	971	350			8.4	155.2			
11.3X31	2	12	5000	41	746	388	28	203	334	794	300	587	709	8.4	158.9			
11.3X31	2	30	5000						447	971	350			8.4	158.9			
9X27	1	12	1600	26	569	211	22	154	286	794	300	587	709	5.31	154.7			
9X27	1	30	1600						397	971	350			5.31	154.7			

GLS = Gear Limit Switch  
DB = Double Brake